

(No Model.)

2 Sheets—Sheet 1.

T. A. EDISON,  
CONVEYER.

No. 602,064.

Patented Apr. 12, 1898.

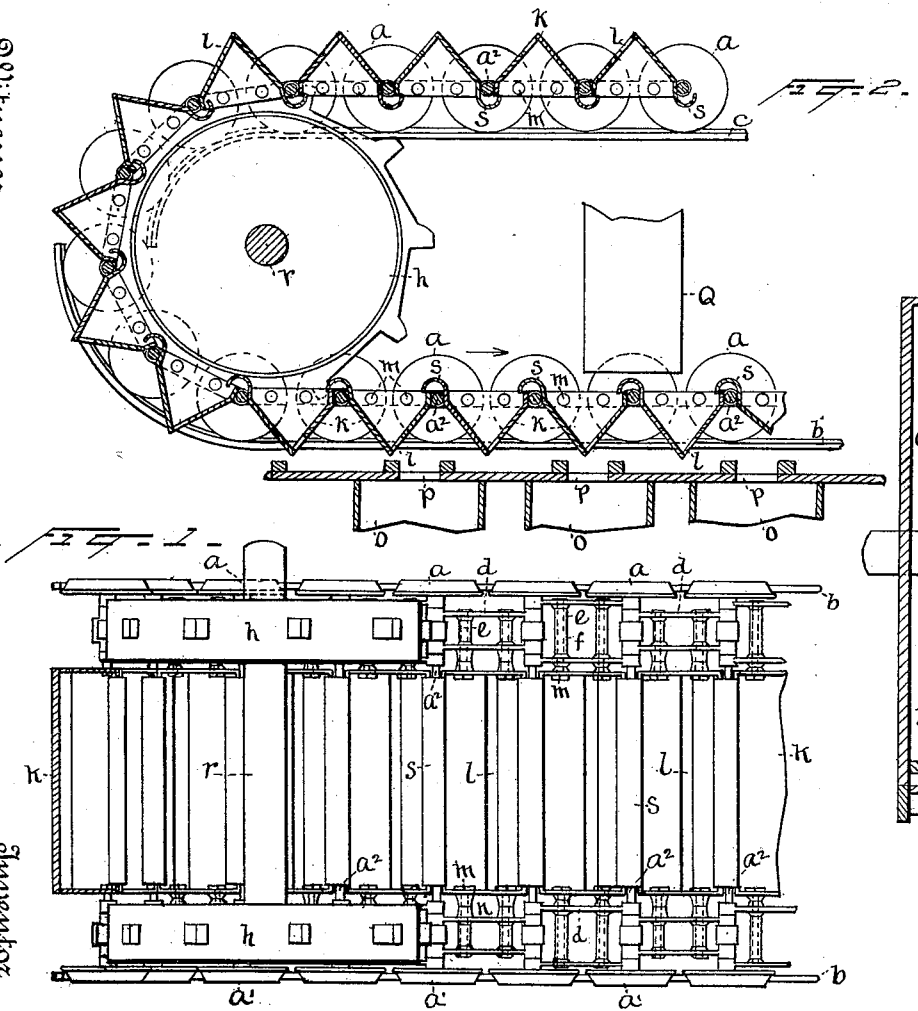
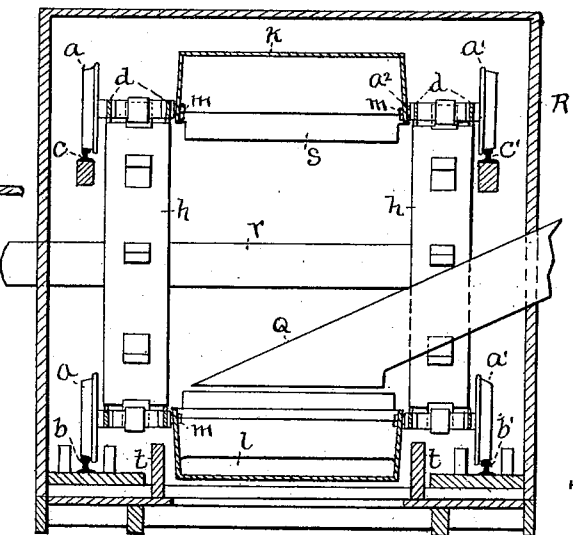

Witnesses  
 Horris A. Clark,  
 Wm. G. Crowl.

Inventor  
 Thomas A. Edison  
 By E. Atkinson  
 Wm. G. Crowl

THE MORRIS PETERS CO. PHOTO-LITHO. WASHINGTON, D. C.

(No Model.)

2 Sheets—Sheet 2.

T. A. EDISON.  
CONVEYER.

No. 602,064.

Patented Apr. 12, 1898.

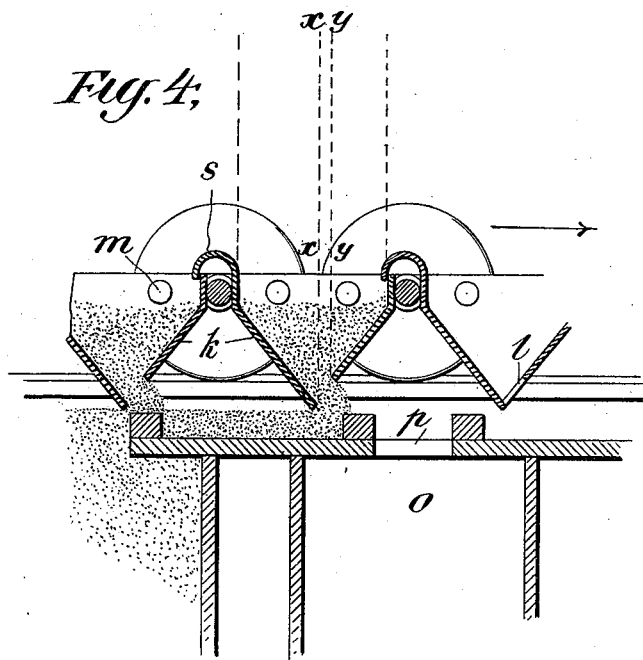

WITNESSES:

*N. K. Hayward*  
*Jno. R. Taylor*

INVENTOR

*Thomas A. Edison*

BY

*Syer & Dunsell*  
ATTORNEYS

# UNITED STATES PATENT OFFICE.

THOMAS A. EDISON, OF LLEWELLYN PARK, NEW JERSEY.

## CONVEYER.

SPECIFICATION forming part of Letters Patent No. 602,064, dated April 12, 1898.

Application filed December 19, 1893. Serial No. 494,122. (No model.)

To all whom it may concern:

Be it known that I, THOMAS A. EDISON, a citizen of the United States, residing at Llewellyn Park, in the county of Essex and State of New Jersey, have invented a certain new and useful Improvement in Conveyers, (Case No. 967,) of which the following is a specification.

My invention relates to conveyers for carrying material from one place to another; and my object is to provide a simple and effective form of conveyer by means of which the material may be continuously carried from one point and continuously delivered to another point or points without any manual interposition.

My invention consists in the novel devices and combinations of devices employed by me in accomplishing the above-named objects, as hereinafter set forth and claimed.

My invention is illustrated in the accompanying drawings.

Figure 1 is a horizontal longitudinal section of a portion of a conveyer embodying my invention with the sprocket-wheels in plan view; Fig. 2, a vertical longitudinal section thereof; Fig. 3, a vertical transverse section of the same; and Fig. 4, a sectional view of a portion of the conveyer, illustrating its operation.

The conveyer consists in general of an endless chain composed of links and provided with wheels running upon a track, said chain engaging with sprocket-wheels which are turned to move the chain and carrying buckets provided with apertures in their bottom. Material being delivered to these buckets successively, it falls from them into the receptacles provided for it as the buckets pass over the mouths of such receptacles.

Wheels *a* on one side of the conveyer are joined to wheels *a'* on the other side by shafts or axles *a<sup>2</sup>*. These wheels run on rails *b b'* of the lower track and on rails *c c'* of the upper track, both tracks terminating at the ends of the conveyer, as shown—that is to say, they being curved toward each other, but with their meeting ends in different vertical planes, so that the wheels pass from one track to the other as they round the ends of the conveyer.

It has been considered necessary in Figs. 1 and 2 to illustrate only one end of the con-

veyer, the other end being the same in all respects.

The shafts of the wheels are joined together on each side of the conveyer by links which consist of bars *d d*, having eyes in their ends, through which eyes the wheel-shafts pass, said bars being thus sleeved on the wheel-shafts.

The bars *d d* of each side are joined together by bolts *e e*, provided with sleeves *f f*, and these bolts serve also to support the buckets which carry the material, as will be presently explained. It will be observed that alternate links are wider than the others, this being required to enable the sleeving of the links upon the shafts *a<sup>2</sup>*.

It will be seen that there is formed a double endless chain supported by the wheels *a a'* and adapted to travel by means of said wheels upon the track-rails, the track being beneath the wheels in all positions thereof.

The chain derives motion from the sprocket-wheels *h h*. Two similar wheels are placed at the opposite end of the conveyer. The teeth of the sprocket-wheels engage with the links of the chain, as the drawings show, so as to move the chain in the direction indicated by the arrow in Fig. 2.

Supported between the two sides of the chain are the buckets *k k*. These are preferably of the triangular form shown, and each is provided at its bottom with the slit or aperture *l*, extending across the bucket. The ends of the bolts *e e* pass through the end walls of the buckets, and such walls are clamped firmly between nuts *m* and sleeves *n* on the bolts, each bucket being secured to two opposite links of the chain and being free to move as such links may move on the wheel-shafts. Said wheel-shafts pass between the buckets, and in order to prevent the material intended to be deposited in the buckets from falling between them and to protect the shafts one of the side walls *s* of each bucket is extended upwardly and over the space between the buckets and the edge of the next bucket, whereby all the delivered material is guided into the buckets themselves.

The conveyer is preferably situated above a series of bins or receptacles *o o*, having apertures *p p* in their upper sides.

*Q* represents a suitable chute, through

which the material to be conveyed is allowed to flow in a stream, such material entering the buckets *k k* as they pass successively under the chute. The receptacles *o o* are placed  
 5 under such portion of the conveyer as desired, the drawings being intended to show only their general relation to the conveyer, and the material in the buckets is continuously deposited in said receptacles through  
 10 the openings in their tops as the conveyer moves, to be withdrawn from such receptacles as occasion requires.

If it is not desired to use any particular receptacle, the opening thereof may be closed  
 15 by any suitable cover and the material will then be carried forward by the buckets until the next opening is reached.

Guards *t t* are placed along the buckets, near the ends of the openings, to insure the  
 20 material entering the receptacles and prevent its working toward the rails.

The entire conveyer may be inclosed in a suitable inclosing box or structure *R*, as shown in Fig. 3, forming a chamber in which  
 25 the conveyer moves, the shafts *r* of the sprocket-wheels extending through the walls of the chamber.

The lower track is supported upon any suitable foundation, as indicated in the drawings. I have not considered it necessary to  
 30 illustrate the supporting-framework for the upper track, since this may be of any suitable character and to illustrate it would tend to obscure the illustration of the more essential features of the apparatus.

In Fig. 4 the operation of the conveyer is shown. The buckets *k*, containing material, scrape along over the platform, piling up material in front of them, so as to block the  
 40 opening *l* in the lower part of the forward side of each bucket. This prevents the discharge of material from the bucket until a receptacle which is not filled is reached, when the material has nothing to prevent its flowing into  
 45 the mouth of the receptacle. When a receptacle is filled, there being no break in the surface over which the buckets scrape, the material in the buckets is carried to the next unfilled receptacle. It will be seen that the level  
 50 of the material upon the platform will be automatically maintained, so that the buckets will have to push before them only enough material to block the openings *l*. The dotted lines in Fig. 4 show that most of the material  
 55 is supported by the sides of the bucket or scraper, there practically being only the weight of material embraced between the lines *x x* and *y y* to be supported by the mound scraped up in front of the advancing bucket.

Thus while getting the automatic distribution, which is the chief aim of the ordinary scraping-conveyer, but little more power is necessary to operate the conveyer than in the ordinary forms of bucket conveyer, where the  
 60 material is supported and conveyed on wheels instead of being forced in front of scrapers or flights. Thus in a very simple manner are

combined the automatic distribution of a scraping-conveyer and the economy of operation of a carrying-conveyer, the chief advantages of these two kinds of conveyers. 70

In operation the several conveying-buckets after receiving material begin to discharge it through the openings *l*, immediately upon the platform seen in the drawings in line with the  
 75 mouths of the pockets *o* and also directly into the pockets, and material is moved by the scraping action of the advancing buckets into the pockets. When a pocket is full, it is obvious that the material which is moved along  
 80 by the lower edge of the buckets tends to close the opening *l* therein until a pocket is reached sufficiently empty to receive the material. In this way and by these means a number of pockets may be automatically filled  
 85 and kept full, and the material will be properly distributed. Furthermore, by reason of the fact that material in front of the buckets closes the openings therein, it will be seen that the buckets do not tend to discharge material when over pockets which are already filled. 90

What I claim is—

1. A conveyer having an endless series of buckets, each having an opening in the bottom and one wall of each bucket forming a  
 95 scraper, whereby the scraping action of the buckets serves to control automatically the discharge of material therefrom, substantially as set forth. 100

2. A scraping-conveyer having each one of its scrapers or flights in the form of a bucket with an opening in the lower part of the forward side of such bucket, whereby the scraping  
 105 action of such bucket serves to control automatically the discharge of material from the buckets, substantially as set forth.

3. In a conveyer, the combination of an endless chain of moving buckets having openings in their bottoms, means for delivering  
 110 material to said buckets, and means for effecting a distribution of such material, consisting of a platform over which said buckets move from the place of receiving to the place of delivery of such material, and a series of  
 115 receptacles having openings in said platform directly under the line of movement of said buckets, substantially as set forth.

4. The combination of an endless chain of buckets having openings in their bottoms, means for delivering material to said buckets, a series of open receptacles situated beneath  
 120 said buckets, and a platform above the upper ends of said receptacles, and over which the material is moved by the scraping action of said buckets, substantially as set forth. 125

5. The combination of an endless chain of buckets having openings in their bottoms, said openings facing the direction in which the buckets are moved, means for delivering  
 130 material to said buckets, a series of open receptacles situated beneath said buckets, and a platform above the upper ends of said receptacles, and over which the material is

moved by the scraping action of said buckets, substantially as set forth.

6. The combination of an endless chain of buckets having openings in their bottoms, means for delivering material to said buckets, a series of open receptacles situated beneath said buckets, a platform above the upper ends of said receptacles, having openings therein into said receptacles and over which the material is moved by the scraping action of said

buckets, and vertical sides for said platform between which the said buckets operate, substantially as set forth.

This specification signed and witnessed this 13th day of December, 1893.

THOS. A. EDISON.

Witnesses:

JOHN F. RANDOLPH,  
HARRY F. MILLER.