

(No Model.)

T. A. EDISON.  
DYNAMO ELECTRIC MACHINE.

No. 298,955.

Patented May 20, 1884.

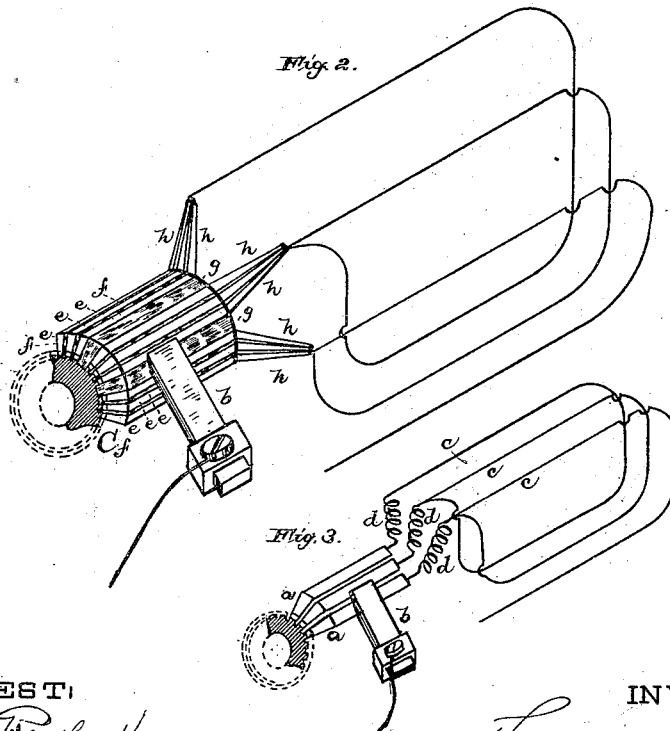
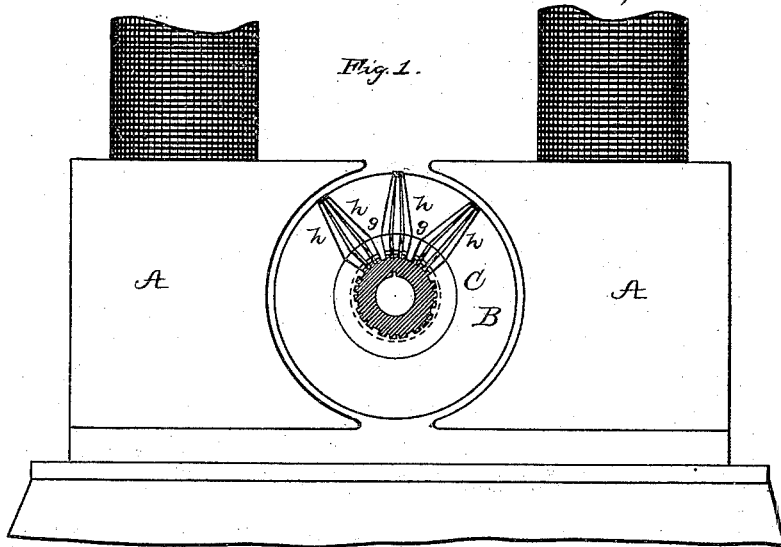

ATTEST:  
*W. B. Rowland*  
*W. B. Rowland*

INVENTOR:  
*Thomas A. Edison*  
*Per Rich. M. Dyer*  
*A. W. S.*

# UNITED STATES PATENT OFFICE.

THOMAS A. EDISON, OF MENLO PARK, NEW JERSEY.

## DYNAMO-ELECTRIC MACHINE.

SPECIFICATION forming part of Letters Patent No. 298,955, dated May 20, 1884.

Application filed December 12, 1883. (No model.)

*To all whom it may concern:*

Be it known that I, THOMAS A. EDISON, of Menlo Park, in the county of Middlesex and State of New Jersey, have invented a new and useful Improvement in Dynamo-Electric Machines, (Case No. 601,) of which the following is a specification.

In my Patent No. 276,233 is set forth the use of current-collectors for electrical generators and motors of high resistance, whereby the local current set up when a current-collector bridges the commutator bars is weak, and little or no spark is produced by the breaking of the local circuit.

This invention relates to a different means for producing the same result; and it consists, mainly, in the use of connections of high resistance between the commutator-bars and the armature-coils of dynamo-electric machines and electro-dynamic motors; and it further consists in making this connecting resistance variable, so that a greater resistance is in the local circuit when the brush leaves a bar than when it is resting on said bar, this being accomplished by dividing each commutator-bar into several parts, all the parts of each bar being connected separately to the same coil of the armature, so that only one connection, and consequently the highest resistance, is interposed in the local circuit at the moment when the current-collector leaves the bar, whereby the spark is much lessened or entirely done away with.

The above may be better understood by reference to the annexed drawings, in which Figure 1 is a view in elevation of a portion of a dynamo-electric machine embodying my invention, the commutator-cylinder being in section. Fig. 2 is a view of a part of the commutator-cylinder, with a diagram of the armature-coils; and Fig. 3, a similar view illustrating the simplest form of the invention.

Referring first to Fig. 3, *aa* represent conducting-bars on the commutator-cylinder of a dynamo-electric machine. A commutator-brush, *b*, rests upon the bars. *cc* are coils upon the armature of the machine, and the connections of these coils with the respective commutator-bars are made through resistances *dd*. These resistances may be in the form of

coils of wire, or thin strips of German silver, or other high-resistance metal; or any other suitable material in convenient form may be employed. The local circuit formed when the brush bridges two commutator-bars must include two of these resistances *d*, and consequently a weak current only can be generated in such circuit, incapable of producing any considerable spark when the circuit is broken.

Referring now to Figs. 1 and 2, *AA* are the poles of the field-magnet, and *B* is the armature of a dynamo-electric machine. *C* is the commutator-cylinder. Each of the ordinary bars upon its surface is divided into three parts, *eee*, separated by mica, *f*, or other suitable insulation. Mica insulation *g* separates the divided bars from one another. All the divisions of a bar are connected at the same point to the armature-coils, the connections preferably being through resistances. Strips *h*, of German silver, are shown for forming these connections. These strips are attached to the commutator-bars, and the armature-coils to the strips in any suitable manner. When the brush *b* bears on all the divisions of a commutator-bar, the three connecting-strips *h* of that bar are all in circuit; but when it is upon the last division alone only one connecting-strip is in circuit, so that a high resistance is in circuit at the time when the circuit is broken by the brush leaving the last division of the bar.

I do not claim herein the use of resistances external to or separate from the current-collectors, forming bridges of high resistance between the commutator-bars, for this forms the subject of my application No. 600, (Serial No. 111,281.)

What I claim is—

1. In a dynamo-electric machine, the combination, with the commutator-bars and the armature-coils, of high-resistance connections between them, substantially as set forth.

2. In a dynamo-electric machine, the combination, with the commutator-bars and the armature-coils, of connections between them of varying resistance, the highest resistance being in circuit when the current-collector leaves a bar, substantially as set forth.

3. In a dynamo-electric machine, the divid- 100

ed commutator-bars, all the divisions of a bar being connected at the same point to the armature-coils, substantially as set forth.

4. In a dynamo-electric machine, the combination, with the armature-coils and the commutator-bars, of connecting-strips of high-resistance material between them, substantially as set forth.

5. In a dynamo-electric machine, the combination of the divided commutator-bars, the

armature-coils, and the connecting-pieces of high-resistance material, all the divisions of a bar being connected at the same point to the armature-coils, substantially as set forth.

This specification signed and witnessed this 15th day of November, 1883.

THOS. A. EDISON.

Witnesses:

H. W. SEELY,

EDWARD H. PYATT.